



20 twenty years of advanced solutions for gas detection

Gas Sensing Elements Proudly 100% Developed and Manufactured in Italy

# IREF LITE - ppm

## The low-cost, high-performance NDIR sensor for refrigerant detection in ppm range

DS4653 rev.6 dated 16/07/2024



### Key Features

- Standard industrial 7-series size, to fit existing detectors
- No field calibration to reduce maintenance costs
- Superior gas selectivity, to avoid false and undetected alarms
- MTBF of more than 10 years, for greater sensor lifetime
- The most comprehensive range of targeted gases on the market
- Temperature range (-10 to +50 °C), for use in commercial and residential settings
- Fast T90 response time, for critical and life-saving applications
- ModBus or analogue output, for ease of integration
- Internal microprocessor, for advanced signal processing
- Solid, rugged construction available also with aluminium enclosure

### General Description

N.E.T. IREF LITE will make the gas selectivity, accuracy, poison immunity and extended lifetime of NDIR technology affordable for any setting, dramatically improving gas detection performances in the HVAC-R market, improving occupants' safety and lowering cost-of-ownership.

The IREF LITE series from N.E.T. include solutions for R134a, R-410a, R32, R1234yf, R1234ze, R404a, R407c and R449a in ppm range.

N.E.T. IREF implements N.E.T. advanced NDIR, black body and microprocessor technology to eclipse classic semiconductor (MOS) sensor performances, reducing maintenance costs (no field calibration required), increasing sensor lifetime and making your leak detection fail-safe, while offering the best gas selectivity available and a fast response time.

All N.E.T. IR sensors run on a microprocessor-based platform for internal signal processing, providing a linearized and temperature compensated output in digital and analogue format – the ideal solution for instrument manufacturers, even without any specialist knowledge in IR technology.

N.E.T. IR sensor series apply NDIR (Non Dispersive Infrared) detection technique. This technique is based on the fact each gas has an unique and well defined light absorption curve in the infrared spectrum that can be used to identify the specific gas. The concentration can be determined by using a suitable infrared source and analysing the quantity of energy absorbed from the gas inside the optical path.

Infrared gas sensors employ a dual wavelength tech-

nique, using an IR energy source aimed at two pyroelectric detectors, each sensitive to different ranges of wavelengths in the spectrum's infrared portion. The differential absorption technique, where the target gas is always monitored with respect to a reference measurement, attenuates the effect of background distortions due to response to other gases, source aging or optical surface contamination.

The analogue output can be set as standard voltage type [0.4 V–2 V] dc or Threshold mode that provides a user-programmable threshold output consisting of different voltage levels – by default, 10% F.S.=1V, 15% F.S.=2V. The user can freely select the output level, the corresponding output and the hysteresis of the thresholds through Modbus RTU commands.

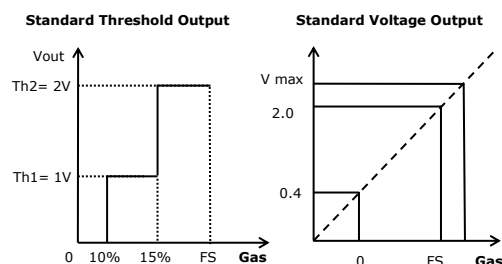

Fig. 1: Characteristics of output voltage

#### N.E.T. SRL

Via Campania, 5 | 20006 | Pregnana Milanese |  
Milano | Italy  
C.F. e P. IVA (VAT) 03231490966

T +39.02.9354.4190  
E info@nenvitech.com  
www.nenvitech.com

## Mechanical specifications

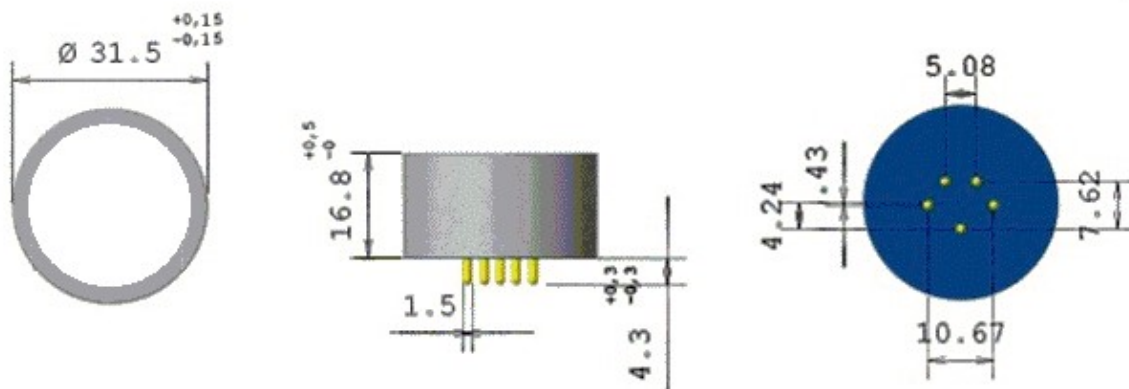

## Pinout

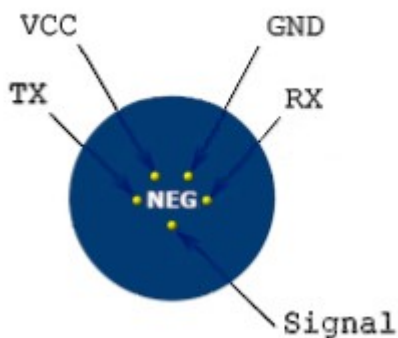

## Digital Communication

Digital Interface	<b>Digital signal format</b>	8 data bits, 1 stop bit, no parity
	<b>Standard Baud rate</b>	4800 bps ad Default; 9600,19200,38400 bps
	<b>TX- VOH: output "High" minimum voltage</b>	2.8V
	<b>TX- VOL: output "Low" maximum voltage</b>	0.5V
	<b>RX- VIH: input "High" minimum voltage</b>	2.3V
	<b>RX- VIL: input "Low" maximum voltage</b>	1.15V

## Warranty and warning

The WARRANTY of IREF-L 32mm sensors is 1 years from the purchased date against defects in materials or production. This warranty however is not valid for articles that have been broken, repaired by a third person or not used according to the instructions contained in this document or supplied with the products, related to the storage, installation, operation, maintenance, or servicing of the products.

Please keep particular attention to:

- Power the sensor observing the correct voltage and polarity
- Never solder directly on the pin, use PCB sockets
- Never cut or remove any of the pins
- Use anti-static precautions when handling the sensor
- Never let water or other liquids to enter inside the sensor
- Never expose the sensor to corrosive gases
- The gas flow used for testing should be  $\leq 500$  SCCM
- Recalibration of the sensor will void the calibration warranty

## Product specifications

General	<b>Operating temperature range</b>	-10 to +50 °C
	<b>Storage temperature range</b>	-40 to +85 °C
	<b>Maximum temperature cycle variations</b>	± 1°C/min
	<b>Operating humidity range</b>	0-95% non condensing
	<b>Operating pressure range</b>	800-1200 mBar
	<b>Gas types</b>	R32; R134a; R1234yf; R1234ze; R404a; R407c; R410a; R449a (Others on request)
	<b>Weight</b>	26 g
	<b>MTBF</b>	≥ 10 years
	<b>Patent information</b>	MI2013A000478, EP14001065, US14/219631, CA2.847.491
	<b>Firmware and digital technology</b>	Designed for use in a detector that complies to EN 50271(SIL1)
	<b>Electromagnetic Compatibility (EMC)</b>	Designed for use in a detector that complies to EN 50270
	<b>Optics</b>	Special optics treated to increase brightness and prevent oxidation
	<b>Enclosure</b>	Aluminium
	<b>Calibration</b>	Individually calibrated with temperature compensation. Test report supplied.
Measurement	<b>Sensing method</b>	NDIR (dual beam technology)
	<b>Measurement range</b>	0-5000 ppm 0 - 10000 ppm (1%vol)
	<b>Repeatability</b>	±3% of FS range
	<b>Accuracy *</b>	±5% of FS range below 50% F.S ±7% of FS range above 50% F.S
	<b>Resolution</b>	0.5% of F.S range
	<b>Long Term Zero Stability</b>	+3% of FS range/year
	<b>Temperature Performance</b>	±7% of FS
	<b>Zero level Humidity Error</b>	±1%
	<b>Response time</b>	T <sub>50</sub> ≤ 10 s; T <sub>90</sub> ≤ 30 s
Electrical	<b>Power voltage</b>	4.5 - 5.5 Vdc
	<b>Operating current</b>	85-115 mA
	<b>Warm up time</b>	60 s for full operation @ 25 °C At least 1 hour for full specification @ 25 °C
	<b>Max output current</b>	±1mA
	<b>DC output impedance</b>	0Ω
	<b>Max capacitance load</b>	100 pF
Signal Output	<b>Threshold mode Analog output</b>	Standard Threshold levels: [1V] Threshold 1 ;[2V] Threshold 2
	<b>Threshold digital levels</b>	Standard Threshold levels: [10%F.S] Threshold 1 ;[15%F.S] Threshold 2
	<b>Analog output (standard for voltage mode)</b>	Standard Voltage [0.4 V—2 V] dc
	<b>Digital communication</b>	MODBUS protocol communication (documentation available on request)

\* Test conditions: 25°C ambient temperature and 1000hPa absolute pressure

## Ordering details

When making an order, we kindly ask our customers to specify the basic physical and electrical properties that are needed for their specific application. This is made through the part number here below. The squared fields of the part number below can be modified according to the options on the right. See DS2203 for complete instructions on how to compile the part number for the entire IR series.

IFL32 - 134 P -NC VS N

Options available :

Output:

VS=Standard Voltage output [0.4 V—2 V] dc  
TH=Standard Threshold mode

Range:

P=5000 ppm  
1= 1%vol (10000ppm)

GAS:

R32 1%vol (10000ppm)  
134=R134a 5000 ppm  
410=R410a 1%vol (10000ppm)  
1YF=R1234yf 5000 ppm  
1ZE=R1234ze 5000 ppm  
47C=R407c 5000 ppm  
404=R404a 5000 ppm  
449=R449a 5000 ppm

N.E.T. has a policy of continuous development and improvement of its products. As such the specification for the device outlined in the data sheet may be changed without notice. In case of modification of the product, N.E.T. disclaims all liability.

No part of this publication may be reproduced, distributed, or transmitted in any form or by any means, including photocopying, recording, or other electronic or mechanical methods, without the prior written permission of N.E.T. For permission requests or technical support please contact or write to the address below:



N.E.T. SRL  
Via Campania, 5 | 20006 | Pregnana Milanese | Milano | Italy  
T +39.02.9354.4190  
E info@nenvitech.com  
www.nenvitech.com

